

FLOW FIELD CHARACTERISTICS OF CIRCULAR-CYLINDER WAKE WITH A NEAR-WAKE WIRE DISTURBANCE

I. Yildirim, C.C.M. Rindt, A.A. van Steenhoven

Faculty of Mechanical Engineering,
Energy Technology Section,

Den Dolech 2, 5600MB, Eindhoven, The Netherlands

i.yildirim@tue.nl, c.c.m.rindt@tue.nl, a.a.v.steenhoven@tue.nl

ABSTRACT

The 3-D transition of the flow behind a circular cylinder with a near-wake wire disturbance has been investigated experimentally. The presence of a wire in the near-wake region of the cylinder causes an unnatural mode of shedding to occur, namely Mode C. Cross-stream plane flow visualization and PIV experiments are done to investigate the influence of the wire on various properties of the flow, such as the dynamics of the spanwise structures. Experiments were performed at Reynolds numbers of $Re = 185, 215$. From these experiments it can be concluded that the Mode C structures are formed as secondary streamwise vortices around the primary von Kármán vortices. The spanwise wavelength of those Mode C structures is determined in the near wake of the cylinder and is approximately 2.2 cylinder diameters. The presence of the wire also triggered the occurrence of period doubling in the wake. Mode C structures shift half the wavelength of the 3-D structures within each shedding cycle, i.e. practically doubling the shedding period. Neither in the natural shedding modes, Mode A and Mode B, nor in forced shedding Mode E this phenomenon is observed.

INTRODUCTION

The transition of the flow behind bluff bodies has been the main topic of research for many decades. Despite the efforts of many scientist and engineers, the mechanism of transition of wakes behind both streamlined and bluff bodies is still a big challenge. The complexity of the problem arises from the nonlinear interactions between the occurring flow structures. The transition of wakes is mostly associated with vortical structures having dominant properties. The formation of those vortices behind bluff bodies is important because of their contribution to the drag and the heat transfer of the body.

The transition of the cylinder wake from 2-D to 3-D exhibits different flow patterns. Those flow patterns are identified as wake transition modes. In his experiments Williamson(1988) showed that the transition basically occurs by the formation of vortex loops and streamwise vortices. In addition, he observed that the Strouhal-Reynolds number curve contains two discontinuities around Reynolds numbers 170 – 180 and 230 – 260. The two discontinuities correspond to the two distinct flow modes, namely Mode A and Mode B. Depending on the experimental conditions Mode A instability can be seen in the Reynolds number range of 160 – 240 and has a characteristic spanwise wavelength of ≈ 4 cylinder diameters. Mode A transition is associated with streamwise vortices as well as waviness in the von Kármán vortices. On the other hand, Mode B instability exists at higher Re numbers and is characterized by streamwise vortices around the von Kármán vortices with a

spanwise wavelength of approximately 1 cylinder diameter. Mode B can be observed at a Reynolds number 200 but for Reynolds numbers larger than 260 Mode B replaces all other transition modes, (Brede *et al.*, 1996; Williamson, 1996).

When some additional disturbances are added to the flow, the wake transition changes and new 3-D transition regimes occur. This type of wake transition is called forced wake transition. The forced wake transition can be triggered by external disturbances, such as placing a small-diameter control cylinder in the near wake or heating the cylinder. Placing an additional control cylinder behind a cylinder has been a widely studied subject. Strykowski and Sreenivasan(1990) showed that at low Reynolds numbers vortex shedding behind a cylinder can be controlled by placing a small control cylinder behind it. According to them the presence of the control cylinder reduces the temporal growth rate of disturbances and changes the local stability by smearing and diffusing concentrated vorticity by diverting a small amount of fluid in the near-wake of the cylinder. In addition to those results, recent numerical simulations done by Dipankar *et al.*(2007) showed that a control cylinder reduces the shedding frequency and amplitude of the unsteady fluctuations of the lift, which results in a narrow wake.

The effect of a wire close to the cylinder in the transition regime was studied by Zhang *et al.*(1995). They introduced the Mode C transition. In their study they performed experiments and numerical simulations to evaluate the effect of the wire. They concluded that the presence of a wire in the near wake of the cylinder triggers a new mode of vortex shedding with different length scales compared to the other shedding modes, Mode A and Mode B. Mode C structures have a spanwise wavelength of approximately 1.8 cylinder diameter and appear at Reynolds number ranges of 170 – 270. Mode C transition only appears if a thin control wire is placed parallel to the cylinder in the near wake. In case of symmetric excitation the spanwise wavelength of the structures increases to 2.2 cylinder diameters (Zhang *et al.*, 1995). Carmo *et al.*(2008) performed numerical simulations about the wake transition in the flow around two circular cylinders in staggered arrangements. They concluded that depending on the relative position of the cylinders Mode C transition with period doubling character appears.

Another external disturbance that changes the vortical patterns in the transition regime is heating the cylinder. For a relatively high heat input to the cylinder, $Ri > 0.3$, the cylinder wake becomes three-dimensional at lower Reynolds number than the unheated case, (Kieft *et al.*, 2002; Kieft *et al.*, 2003). Downstream in the wake thermal plumes are seen to escape from the primary von Kármán vortices because of the buoyancy force. If the heat input is increased further, $Ri = 1$, the thermal plumes begin to escape at the formation position and the average wavelength of these

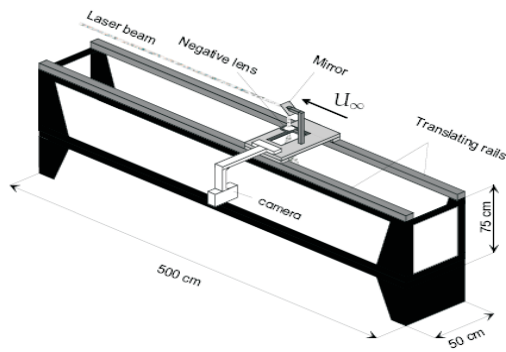

Figure 1: Sketch of the towing tank used for experiments.

structures is around 2 cylinder diameters (Maas *et al.*, 2003; Ren *et al.*, 2004, 2006a, 2006b). This mode of transition is denoted in literature as Mode E, Ren *et al.*(2006a).

The motivation behind this study is to investigate in detail the effect of the wire and the physical process in the formation of Mode C by several experiments. As previous studies showed, despite the different character of the disturbances and different Reynolds number ranges, there exists a similarity between the two different forced convection modes of shedding, Mode C and Mode E. Both modes have 3-D structures with a spanwise wavelength of approximately 2 cylinder diameters. Hence, the main scope of this paper is to evaluate the effect of the wire on the cylinder wake transition and provide information about the flow physics in order to be able to compare the phenomenon to the other shedding modes.

FLOW CONFIGURATION AND EXPERIMENTAL TECHNIQUES

The experiments were performed in the towing tank installed at the Energy Technology Section of Eindhoven University of Technology. It has dimensions $L \times W \times H = 500 \times 50 \times 75\text{cm}$, see Figure 1. The test section has glass walls with a thickness of 15mm and the tank is optically accessible from all directions. The test model is attached to a moving carriage which is pulled along the tank (Ren *et al.*, 2004).

The experimental model is a circular cylinder with a diameter of $D = 15\text{mm}$ and length of $L = 48\text{cm}$. It is placed between circular end plates in order to force parallel shedding. In order to trigger Mode C instability, a wire with a diameter of $d = 0.18\text{mm}$ is placed in the near wake. The ratio of diameter of the cylinder and the wire is $D/d = 83$. The position of the wire is chosen in accordance with the work of Zhang *et al.*(1995) which is $(x/D; y/D) = (0.75; 0.75)$, see Figure 2b.

For the flow visualization experiments the electrolytic tin-precipitation method was used (Maas *et al.*, 2003). This method is based on generation of insoluble small particles on the surface of the model. Those particles are illuminated by a light source and their images are recorded by a camera. In the current set-up the cylinder was covered by a very thin tin-foil and that tin-foil was connected to an electrolysis setup as the anode end. The cathode was placed at a downstream position where it did not disturb the flow. Very small tin hydroxide particles ($O(1\mu\text{m})$) were then generated on the surface of the tin sheet by applying a voltage difference between anode and cathode. When the cylinder is pulled through the water those particles detach from the

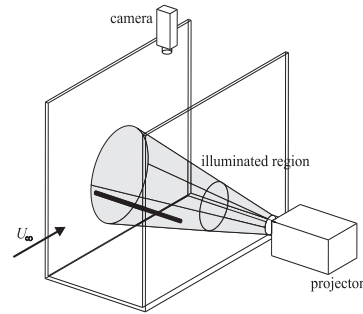

(a) Three-dimensional visualization set-up

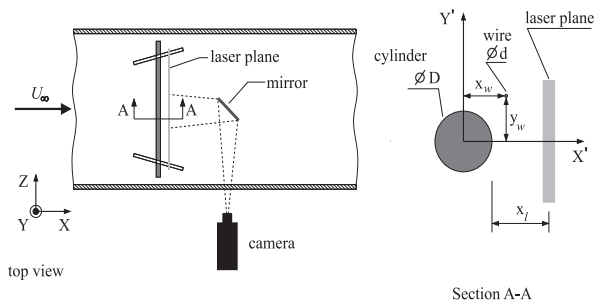

(b) Two-dimensional experiment set-up

Figure 2: Experimental set-up and measurement configurations.

surface and follow the flow.

Flow visualization experiments were performed using two different configurations which can be seen in Figure 2a and Figure 2b. For the visualization of the whole flow field the wake of the cylinder was illuminated by a slide projector and the camera was mounted on top of the setup. The second configuration was used for two dimensional visualization and velocity measurements in the wake, see Figure 2b. In order to visualize the streamwise vortices a mirror was placed in the wake of the cylinder. The center of the mirror lied at a distance of $16D$ downstream of the cylinder, such that the dynamics of the near wake was not influenced. Later on this was verified by visualization experiments. In the two dimensional configuration the flow was enlightened by a laser sheet which is oriented along the $Y - Z$ plane. The images were recorded via the camera placed on the side of the tank.

The quantitative evaluation of the flow was done by using particle image velocimetry (PIV). For this purpose, the water in the towing tank was seeded with PSP particles having a diameter of $20\mu\text{m}$. The same configuration and set-up used for two dimensional flow visualization experiments was also used for PIV experiments, see Figure 2b. The flow was illuminated by using a Nd-Yag laser and the images were captured by an 10-bit camera with $1k \times 1k$ pixel resolution and 29Hz frame rate. The field of view of the camera corresponded to an area of approximately $6D \times 6D$ in the measurement plane. The acquired images were analyzed by using multi-grid interrogation algorithm with $24px \times 24px$ interrogation window size and %50 overlap. The value of the spatial resolution relative to the cylinder diameter was $\approx 0.07D$.

RESULTS

As a first step, the influence of a wire on the cylinder

wake flow was investigated by three dimensional flow visualizations which revealed the general physics of the Mode C structures. Figures 3 and 4 show the image sequences taken during experiments for $Re = 185$ and $Re = 215$, respectively. The former Reynolds number is slightly over the threshold value of 170 which was given by Zhang *et al.* (1995) for the onset of Mode C instability. The original images were recorded by a digital camera and later on processed by image processing software. In the page coordinate system the cylinder is on the top and the flow direction is from top to bottom. The time difference between each consequent snapshot from left to right in both figures is one shedding period which is denoted as T_{shed} in the figures.

The obtained image sequences are first used for a rough calculation of the shedding period. For $Re = 185$, Figure 3, the shedding period and the equivalent Strouhal number were found to be $T_{shed} = 6.48s$ and $St = 0.188$ respectively. When the Reynolds number is further increased to 215, Figure 4, the calculated shedding period and the Strouhal number become $T_{shed} = 5.41s$ and $St = 0.193$ respectively.

The results in Figure 3 and Figure 4 show that the formed 3-D structures are actually secondary streamwise vortices around the primary von Kármán vortices with a spanwise wavelength of approximately 2 cylinder diameters. The formation the Mode C structures starts in the formations region of the cylinder wake. Further examination of the instantaneous image sequences in both figures reveal an interesting feature of the Mode C transition. In both the left and in the middle snapshots, the wake behind the cylinder has the same 3-D structures but with a shift of approximately 1 cylinder diameter in spanwise position. The structures which appear on the line on the left snapshot appear again on the line after 2 shedding periods. So, effectively, the shedding period has become 2 shedding cycles. This feature is called period doubling which is seen in both $Re = 185$ and $Re = 215$ cases and which is not seen in natural wake transition of a cylinder.

A two dimensional visualization of the streamwise vortices is shown in Figure 5. The images in the figure are obtained for $Re = 185$ using the mirror setup as presented in Figure 2b. In the page coordinate system the flow direction is out of the page and the wire is located in the upper side of the cylinder. The time difference between the images in the figure is one quarter of the shedding period T_{shed} . At $t = 0$ mushroom-like shapes are visible with a spanwise wavelength of approximately two cylinder diameters. These mushroom type structures create the two streamwise vortices rotating in opposite directions. Period doubling can also be seen in Figure 5 when the snapshots at instants $0, T_{shed}$ and $2T_{shed}$ are compared.

Figure 6 shows the results of quantitative measurements with particle image velocimetry. In the figure the time evolution of the isocontours of streamwise vorticity are shown. The time difference between the images in the figure is again one quarter of the shedding period T_{shed} . The dark regions in the figure point out high vorticity values in absolute sense. The negative vorticity regions are indicated by dashed contour lines. The vorticity regions indicate the intersection of streamwise vortices with the cross-flow measurement plane. The high regions of vorticity seen at the time instants $0, T_{shed}$ and $2T_{shed}$ show the secondary vortices, namely Mode C vortices. Halfway the cycle at $t = \frac{1}{2}T_{shed}$ and $t = \frac{3}{2}T_{shed}$ the footprints of Mode C vortices appear at the same position but more weaker and with different rotation direction. The Mode C structures are distributed evenly in the upper part and along the axis of the cylinder with the

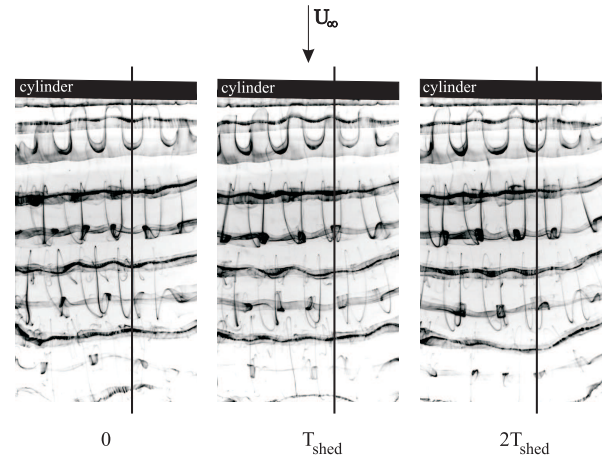

Figure 3: Top-view visualization of Mode C structures at $Re = 185$. Flow is from top to bottom.

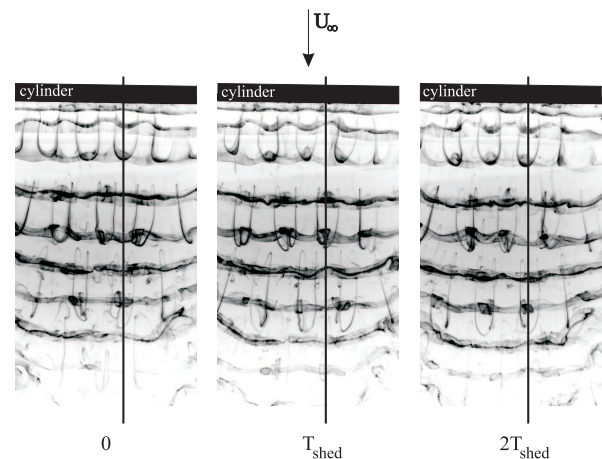

Figure 4: Top-view visualization of Mode C structures at $Re = 215$. Flow is from top to bottom.

spanwise wavelength $\lambda_z \approx 2.2D$. This wavelength remains almost constant throughout time at the measurement plane, i.e. $x_l/D = 2$.

CONCLUDING REMARKS

In conclusion, the current investigation aims to provide additional knowledge about the flow physics of the cylinder wake under the disturbance of a very thin wire. Therefore the flow behind a circular cylinder with a wire in the near wake has been investigated for Reynolds numbers for 185 and 215 in the 3-D transition regime. The information about the flow physics obtained by flow visualization and particle Image Velocimetry experiments. The experiments revealed that by placing a small control wire parallel to the cylinder at $x/D = 0.75$ and $y/D = 0.75$ the shedding pattern behind the cylinder changed dramatically and Mode C transition appeared in the wake. The wavelength of the Mode C structures are calculated from PIV vorticity fields and found to approximately 2.2 cylinder diameters. The comparison of Mode C with the other modes cylinder wake dynamics found in the literature is shown in Table 1. Mode C differs from the natural modes Mode A and Mode B both in the sense of formation and vortex dynamics. On the other hand, despite the different external disturbance, secondary structures in Mode C and Mode E have approximately the same spanwise wavelength. The flow physics of Mode C include

Table 1: Comparison of Mode C findings with properties of different modes of cylinder wake dynamics found in literature.

	Mode A	Mode B	Mode C	Mode E
<i>Re</i> number range	180 – 194	<i>Re</i> > 230	170 – 270	75 – 117
External disturbance	–	–	wire	heat
Spanwise wavelength (λ_z/D)	≈ 4	≈ 1	$\approx 2.2^1$	≈ 2
Period doubling	No	No	Yes ¹	No

another interesting phenomenon which is called period doubling. Mode C structures shift half the wavelength of the 3-D structures within each shedding cycle, i.e. practically doubling the shedding period. Neither in the natural shedding modes, Mode A and Mode B, nor in forced shedding Mode E this phenomenon is observed. The effect of the wire in the appearance of period doubling is yet to be investigated in more detail.

REFERENCES

Brede, M., Eckelmann, H., and Rockwell, D., 1996, "On the secondary vortices in the cylinder wake", *Physics of Fluids*, Vol. 8, pp. 2117-2124.

Carmo, B., Sherwin, S.J., Bearman, P.W., and Willden, R.H.J, 2008, "Wake transition in the flow around two circular cylinders in staggered arrangements", *Journal of Fluid Mechanics*, Vol. 597, pp. 1-29.

Dipankar, A., Sengupta, T., and Talla, S. B., 2007, "Suppression of vortex shedding behind a circular cylinder by another control cylinder at low Reynolds number", *Journal of Fluid Mechanics*, Vol. 573, pp. 171-190.

Gerrard, J. H., 1966, "Mechanics of the formation region of vortices behind bluff bodies", *Journal of Fluid Mechanics*, Vol. 25, pp. 401-413.

Kieft, R. N., Rindt, C. C. M., and van Steenhoven, A. A., 2002, "Heat induced transition of a stable vortex street", *International Journal of Heat and Mass Transfer*, Vol. 45, pp. 2739-2753.

Kieft, R. N., Rindt, C. C. M., van Steenhoven, A. A., and van Heijst, G. J. F., 2003, "On the wake structure behind a heated horizontal cylinder in cross-flow", *Journal of Fluid Mechanics*, Vol. 486, pp. 189-211.

Maas, W.J.P.M., Rindt, C.C.M., and van Steenhoven, A.A., 2003, "The influence of heat on the 3D-transition of the von Karman vortex street", *International Journal of Heat and Mass Transfer*, Vol. 46 (16), pp. 3069-3081.

Ren, M., Rindt, C. C. M., and van Steenhoven, A. A., 2004, "Experimental and numerical investigation of the vortex formation process behind a heated cylinder", *Physics of Fluids*, Vol. 16, pp. 3103-3114.

Ren, M., Rindt, C.C.M., and van Steenhoven, A.A., 2006a, "Three-dimensional transition of a water flow around a heated cylinder at $Re = 85$ and $Ri = 1.0$ ", *Journal of Fluid Mechanics*, Vol. 566, pp. 195-224.

Ren, M., Rindt, C. C. M., and van Steenhoven, A. A., 2006b, "Lift-up process in a heated- cylinder wake flow", *Physics of Fluids*, Vol. 18.

Strykowski, P.J. and Sreenivasan, K. R., 1990, "On the formation and suppression of vortex shedding at low Reynolds numbers", *Journal of Fluid Mechanics*, Vol. 218, pp. 71-107.

Williamson, C.H.K., 1988, "The existence of two stages in the transition to three-dimensionality of a cylinder wake",

Physics of Fluids, Vol. 31 (11).

Williamson, C.H.K., 1996, "Three-dimensional wake transition", *Journal of Fluid Mechanics*, Vol. 328, pp. 345-407.

Zhang, H.-Q., Fey, U., Noack, B. R., Konig, M., and Eckelmann, H., 1995, "On the transition of the cylinder wake", *Physics of Fluids*, Vol. 7 (4), pp. 779-794.

¹Based on present study ($Re = 185$ and 215).

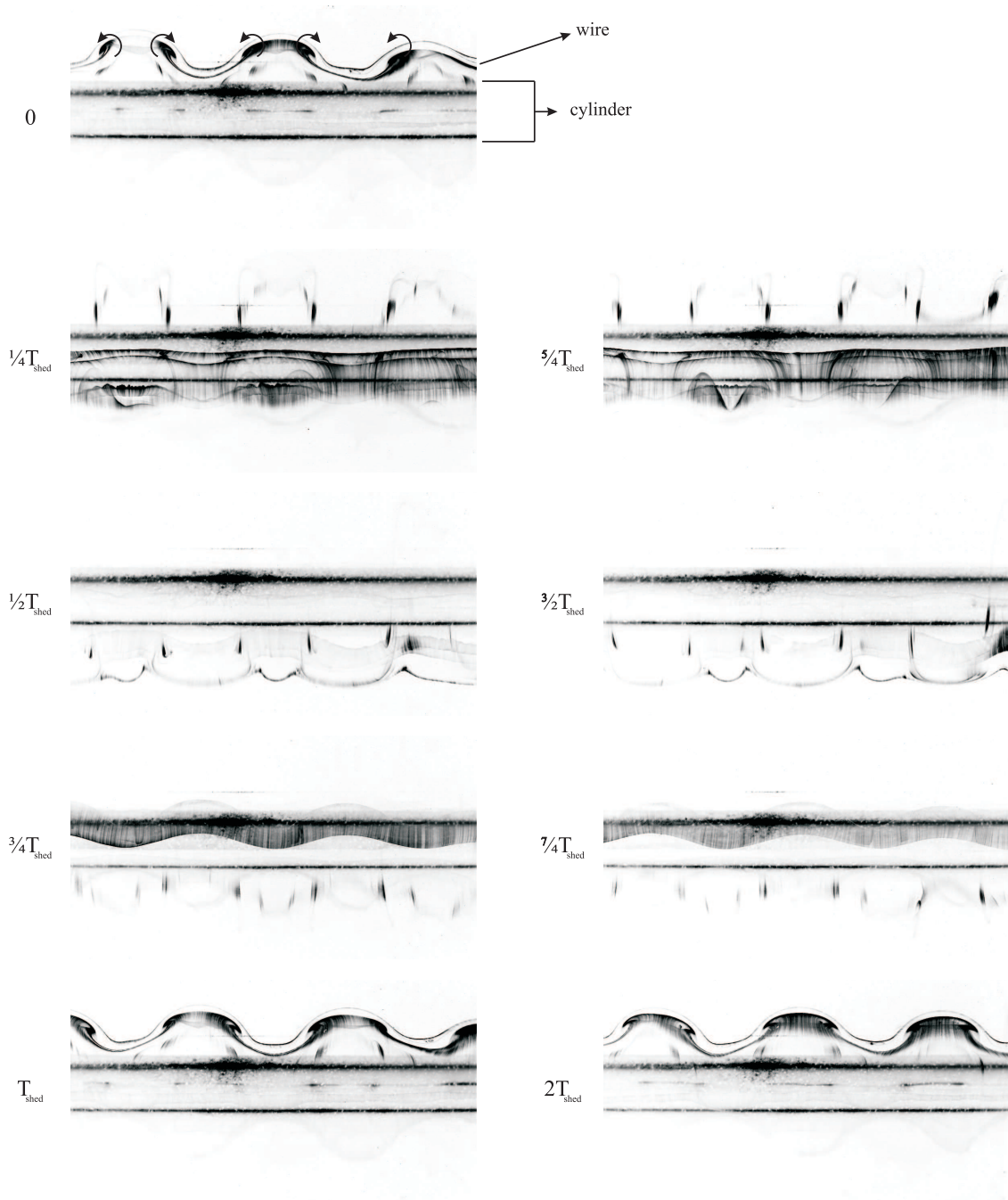

Figure 5: Back-view visualization of Mode C structures; $Re = 185$, $x_l/D = 2$. Main flow direction is towards the reader.

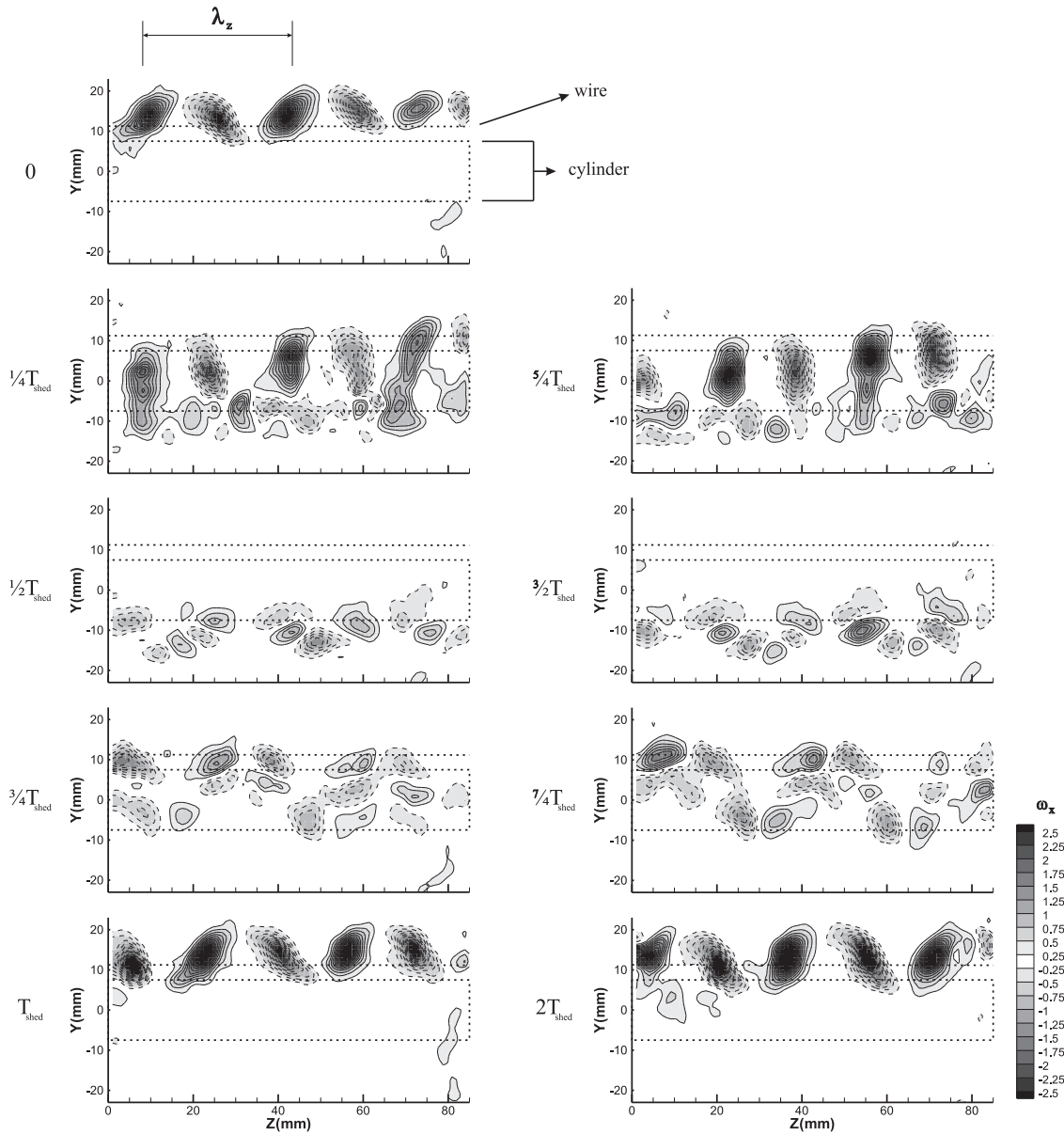

Figure 6: Time evolution of streamwise vorticity (ω_x) of Mode C; $Re = 185$, $x_l/D = 2$. Main flow direction is towards the reader.